

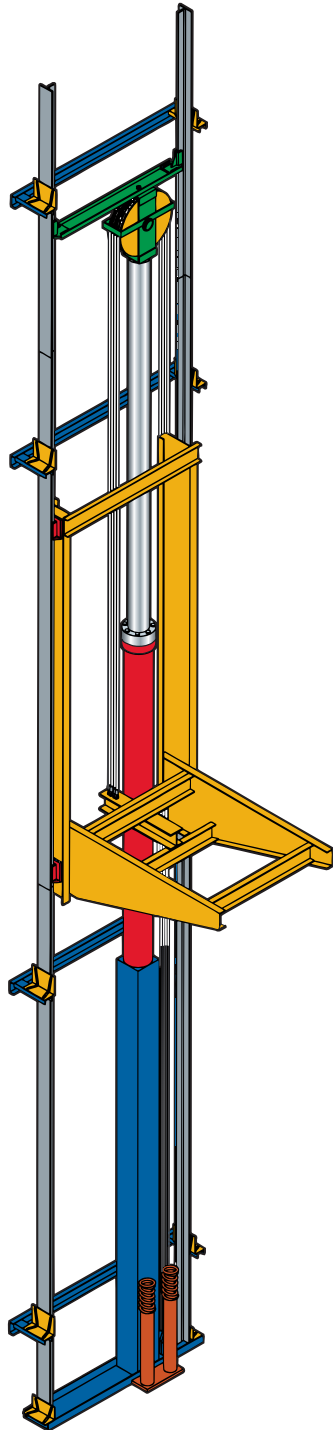

PASSENGER

Cantilever Roped Hydraulic • Front Opening



The Cantilever Roped Hydraulic is a holeless elevator that will serve between 25'-0" and 80'-0" of travel (or more under special conditions). They are manufactured in both 2000-lb. and 2500-lb. capacities.

The platform stability and ride is that of a conventional hydraulic elevator. As with all Canton Elevator products, only the highest quality, industry-standard components are used.

Even more, Canton Elevator dedicated special research and development to this system to help ensure a trouble-free installation. Competitive offerings present the contractor with a multitude of parts. Our approach is to modularize as much as is practical thus reducing on-site time.

This system is not exposed to the potential problems involved with buried cylinder applications. Over-speed governors and car safety brakes are standard on both models.



This information is intended for preliminary planning. We have attempted to include the basic data that you will require in your planning efforts. For details about specific or custom installations please contact your local Canton Elevator representative, or contact us directly.

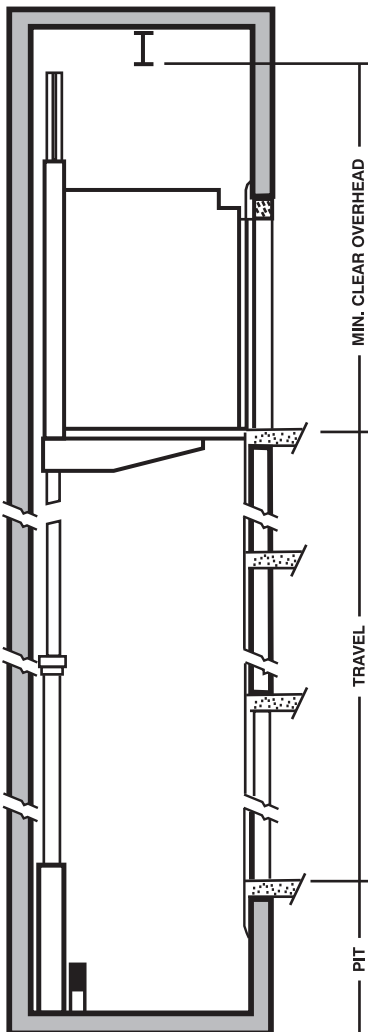

- Pit depth - 4'-6" is standard (can be reduced to 4'-0" if required).
- Min. clear overhead required is based on 8'-0" high cab. For up to 100 FPM = 12'-1". For 100 FPM and over = 12'-4". If available overhead clearance is less than above, cab height can be reduced accordingly to code minimum.
- Speeds up to 150 FPM are standard. Consult the factory for speeds up to 200 FPM.

NOTES:

1. Adequate supports for rail fastenings are required at all rail bracket locations (5'-0" spacing approx.). Concrete or block walls are recommended for support. Inserts should be furnished in block or brick walls. Block walls should be filled with mortar around inserts to provide rigid support.
2. Pit and overhead clearances shown are in accordance with ANSI code requirements.
3. A pit ladder (by others) is required.
4. Top of hatch must be vented in accordance with building codes.
5. A 110V GFI outlet and light are required in the pit.
6. A hoist beam is required (by others) for installation.

MACHINE ROOM

1. An area of 5'-6" x 7'-0" x 8'-0" high is usually adequate for single car installations.
2. A 3'-0" wide door will allow access for the machine room equipment.
3. The recommended location for the machine room is adjacent to the elevator at the lowest landing; however, it can be remotely located if necessary.
4. Adequate heating and ventilation to meet code requirements must be provided.

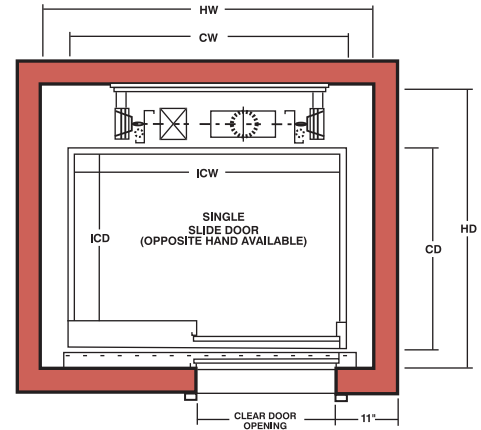

DIMENSIONS	CAPACITY	
	2000#	2500#
HW	7'-4"	8'-4"
HD	6'-10"	6'-10"
CW	6'-0"	7'-0"
CD	5'-1"	5'-1"
ICW	5'-8"	6'-8"
ICD	4'-3"	4'-3"
CLEAR DOOR OPENING	3'-0"	3'-6"

2000# car complies with NEII recommendations for car to accommodate wheelchair.

2500# car complies with NEII recommendations for car to accommodate ambulance size stretcher when equipped with single slide doors.



647 THIRD STREET N.W. • MASSILLON, OH 44647 • PH. 330-833-3600 FAX 330-833-0229

E-Mail info@CantonElevator.com

VISIT OUR WEB SITE

<http://www.CantonElevator.com>