



C65

Inclined Platform Lift

PLANNING GUIDE

Applicable Codes:

ASME A17.1

ASME A18.1

CSA B355

Copyright © 2010
Savaria Corporation
All rights reserved.

Printed in Canada

Purpose of This Guide

This guide assists architects, contractors, and lift professionals to incorporate the C65 Inclined Platform Lift into a residential or public building design. The design and manufacture of the C65 Inclined Platform Lift meets the requirements of the following codes and standards:

- ASME A17.1 – Part 21 (Private), Part 20 (Public)
- ASME A18.1 – Section 6 (Private), Section 3 (Public)
- CSA B355 Safety Standards – S1-02

We recommend that you contact your local authority having jurisdiction to ensure that you adhere to all local rules and regulations pertaining to inclined platform lifts.

IMPORTANT: This Planning Guide provides nominal dimensions and specifications useful for the initial planning of an inclined platform lift project. **Dimensions and specifications are subject to change without notice due to continually evolving code and product applications.**

Before beginning actual construction, please consult Savaria Corporation or the authorized Savaria dealer in your area to ensure you receive your site-specific installation drawings with the dimensions and specifications for your project.

Visit our website for the most recent drawings and dimensions.

How to Use This Guide

- 1 Determine your client's intended use of the lift.
- 2 Determine the local code requirements.
- 3 Determine the site installation parameters.
- 4 Plan for electrical requirements.

History

Initial release – 24-m03-2010

Introduction to the C65 Inclined Platform Lift

The C65 Inclined Platform Lift is an accessibility device used to provide access over stairs with landings, multiple levels, or certain turned staircases. The C65 will transport a passenger either sitting in a wheelchair or on the fold-down seat. The unit travels along the rail at a comfortable speed of 26 feet per minute (8 m/m) up and down the stairway, slowing at corners and turns.

The C65 is easy to operate using the on-board handheld pendant controls. When the lift is not in use, it can be parked and folded up allowing access to the stairs.

The C65 is suitable for either indoor or outdoor use, and can be factory-built for left- or right-side rail installations, and front or side platform access. Typical applications include schools, churches, hospitals, commercial buildings, restaurants, etc.

Major building renovations are usually not required as the C65 is installed on a modular rail system that can be installed for any number of levels. The rails will be securely fastened to a supporting wall, the stairs, or both.

Components of the Lift

Figure 1

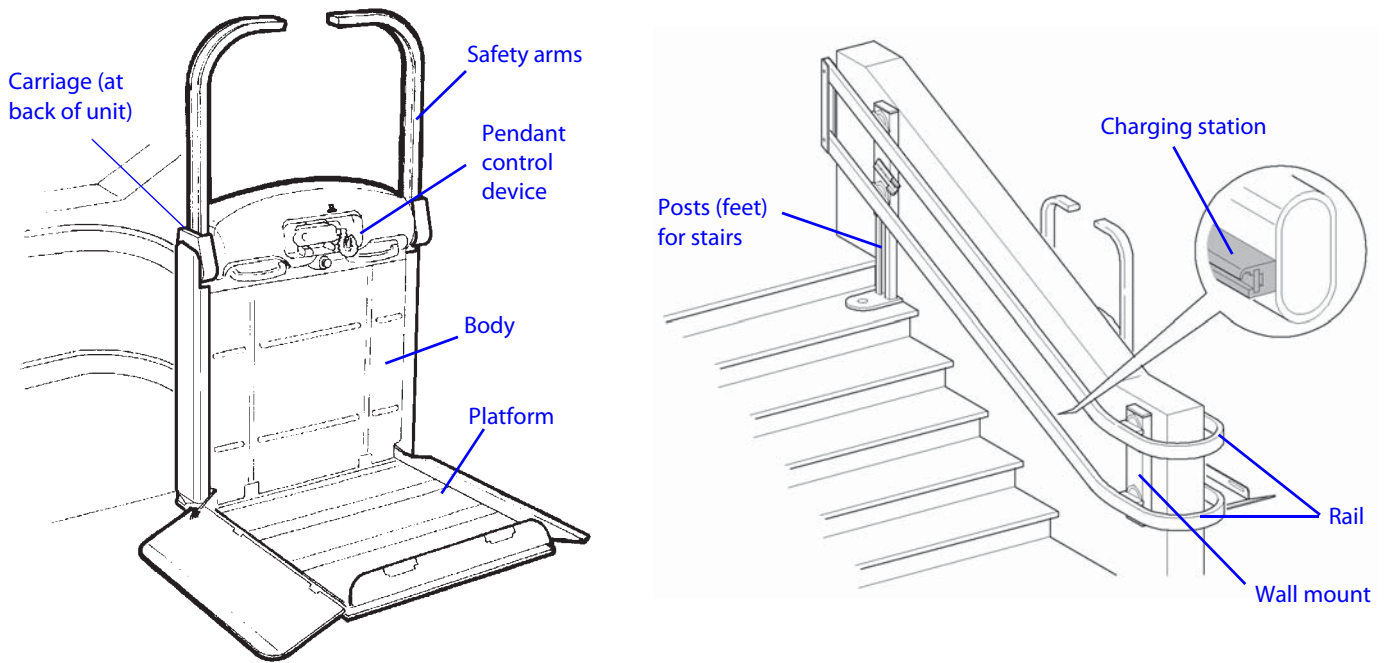
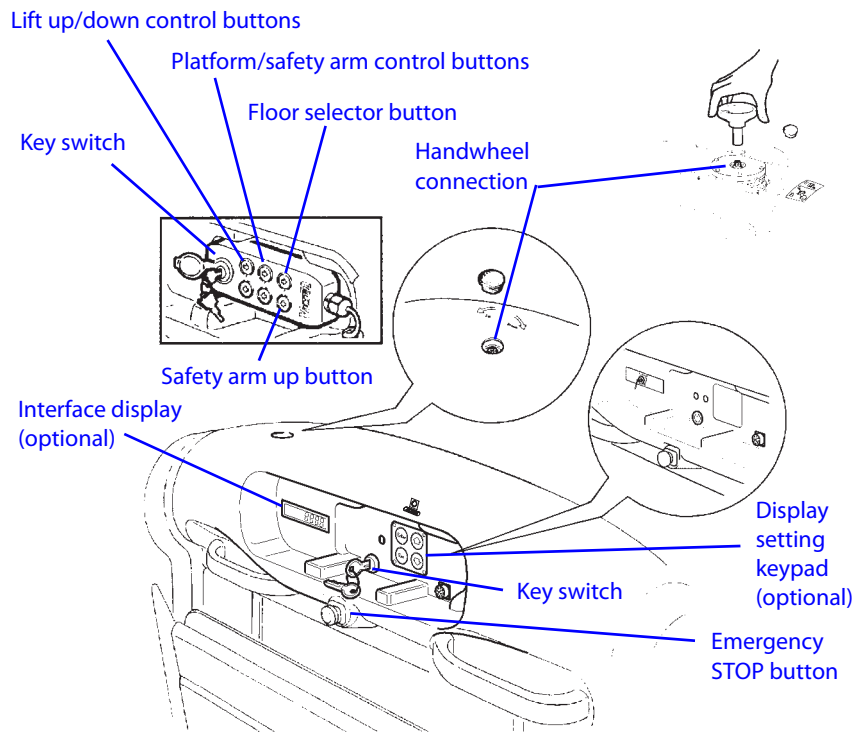

Figure 2



Safety Features

Sensors

During travel, the platform and the body of the lift are protected by sensors which stop the lift if it touches an obstacle (Figure 3). Motion stops upon contact with any obstacle. You can then reverse direction of the unit to remove the obstacle from the travel route.

Safety Arms and Platform Ramps

While in motion, the platform is protected by two safety arms (Figure 3). The platform is also protected by two platform ramps which have the dual function of facilitating access to the lift at the floors (open position) and of retaining the wheelchair while the lift is in motion (safety position).

Before the lift leaves the floor, the safety arms and platform ramps automatically move into the safety position.

The platform ramp facing in the downward direction only opens at the lower floor.

If the safety arms or platform ramps encounter an obstacle as they move into position, a microswitch is tripped, preventing operation of the lift. To restore normal operation, press the reset buttons on the lift control panel.

Handles

The handles (Figure 3) are located in the top of the lift body and can be used as rests while the lift is in motion.

Figure 3

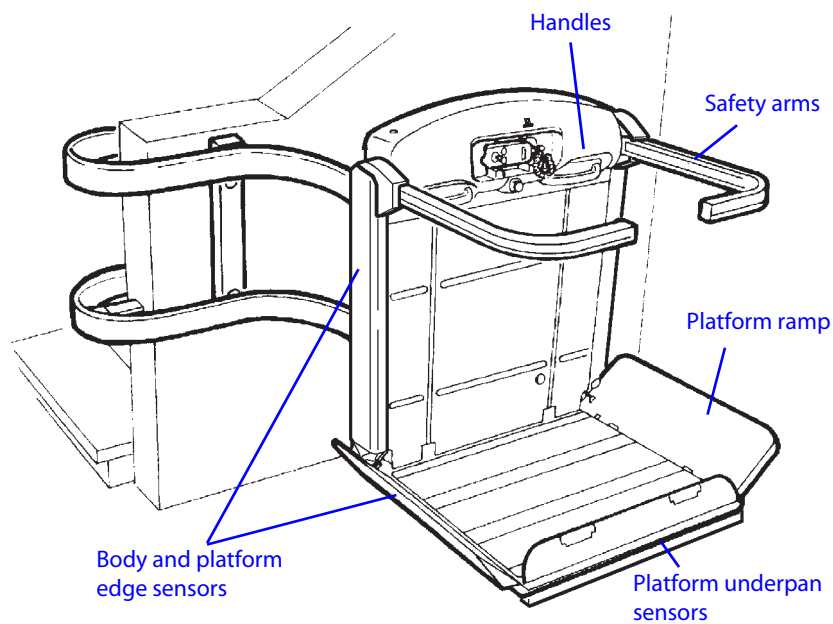

Safety Brake

The lift is equipped with a mechanical safety brake (Figure 4) that has gradual braking. It engages if a drive component fails, or if the normal downward travel speed is exceeded by a preset amount. Application of the brake gradually slows the lift to a stop.

Figure 4

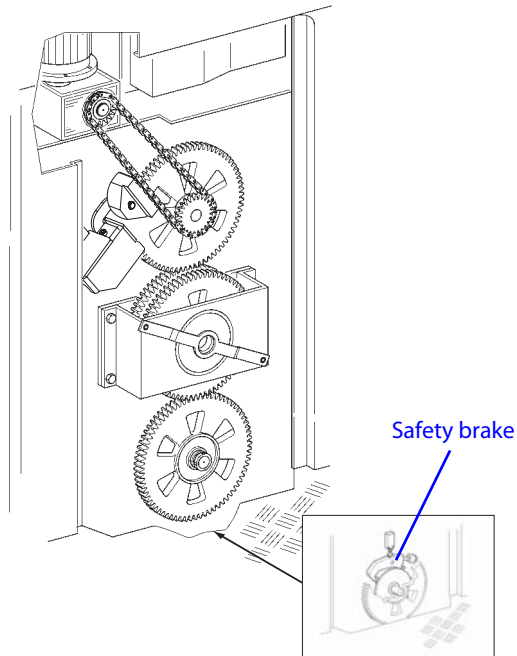

Limit Switches

The home sensor (Figure 5) acts as a limit switch at the bottom floor. The positions of the other floors, including the top floor, are programmed by means of encoders. In the event of a malfunction, a final limit switch stops the lift.

Figure 5

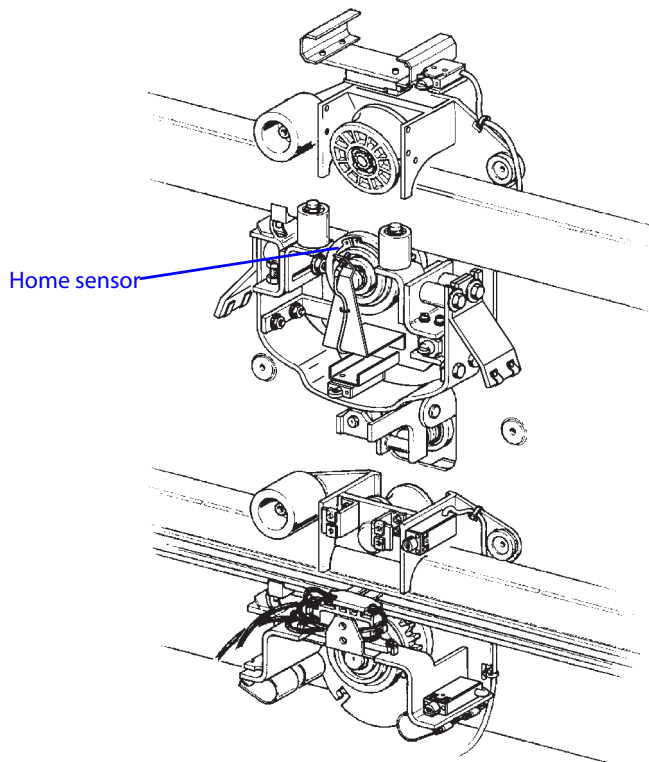

Specifications

C65 Specifications

Specification	Data
Rated load	507 lb (230 kg) up to 45° 440 lb (200 kg) up to 50°
Gradient	From 0° to 50°
Capacity	One person in wheelchair (or sitting on optional seat)
Platform size	49.25" x 31.5" (1250 mm x 800 mm)
Travel speed	26.25 feet/min (8 metres/min)
Travel direction	Forward/backward
Temperature	14 °F to 140 °F (-10 °C to +60 °C)
Humidity	Maximum 70% Not for use in bathrooms or swimming pool areas
Noise	Less than 70 db
Motor	1.35 HP (1 kW), 24 VAC
Power supply	North American: 120 VAC, single-phase, 60 Hz International: 230 VAC, single-phase, 50 Hz
Circuit breakers	North American: 15A, 120V circuit breaker International: 8A, 230V circuit breaker International can contain a differential circuit breaker of 0.3A
Up/down/stop button	Timed (starting delay of 3 seconds)
Emergency STOP button	Immediate stop
Key switch	Enables use of controls
Circuit breaker reset button	To be provided by customer
Standard features	Platform controls (pendant control device) Constant-pressure type control buttons Manual lowering capability (using handwheel) Safety arms Manual folding platform (fold/lower platform by hand) Limit switches No machine room required Emergency stop button
Safety features	Edge sensors Underpan sensors Safety brake Safety arms Platform ramps Handles Emergency stop button Limit switches Manual lowering capability (using handwheel)
Options	Call/send stations at landings Folding seat on platform Motorized folding platform (fold/lower platform using control buttons) Outdoor package Waterproof cover Audio-visual alarm

General

Stairway

Due to close running clearances, the Owner/Agent must ensure that the stairs (where provided) are level, plumb (+/-1/8" (3 mm)) and square and are in accordance with the dimensions specified on the site-specific installation drawings.

Minimum Overhead Clearance

The Owner/Agent must ensure the minimum overhead clearance is in compliance with codes.

Construction Site

The Owner/Agent is responsible for all masonry, carpentry and drywall work as required, and for patching and finishing (including painting) all areas where walls/floors may need to be cut, drilled or altered in any way to permit the proper installation of the lift.

Dimensions

The Contractor/Customer must verify all dimensions on the installation drawings and report any discrepancies to our office immediately.

Installation

The equipment must be installed in compliance with ASME A18.1 1999 code or CSA B355 S1-02 code by a qualified technician.

The conformity for access to the platform is the distributor's responsibility.

Structural

Floor/Support Wall Loads

A structural engineer must ensure that the building and stairway will safely support all loads imposed by the lift equipment. Adequate structural support must be provided at the top landing, bottom landing and throughout the supporting wall along the stairs.

The pull-out force on the supporting wall will vary depending on the type of rail mounting used (wall bracket, or steps and wall posts). The supporting wall must be able to support the pull-out force as identified in the support load diagram below (see dimension A or D).

All wood studs in the supporting wall must be anchored in the ceiling and the floor to meet the pull-out force requirements. Wood studs must be placed at 16" (404 mm) centres.

The floor load will vary depending on the type of rail mounting used (wall bracket, self-supporting posts, or steps and wall posts). The floor must be able to support the loads identified in the support load diagram below (see dimension B, or C and E).

Figure 6: Support Load Diagram

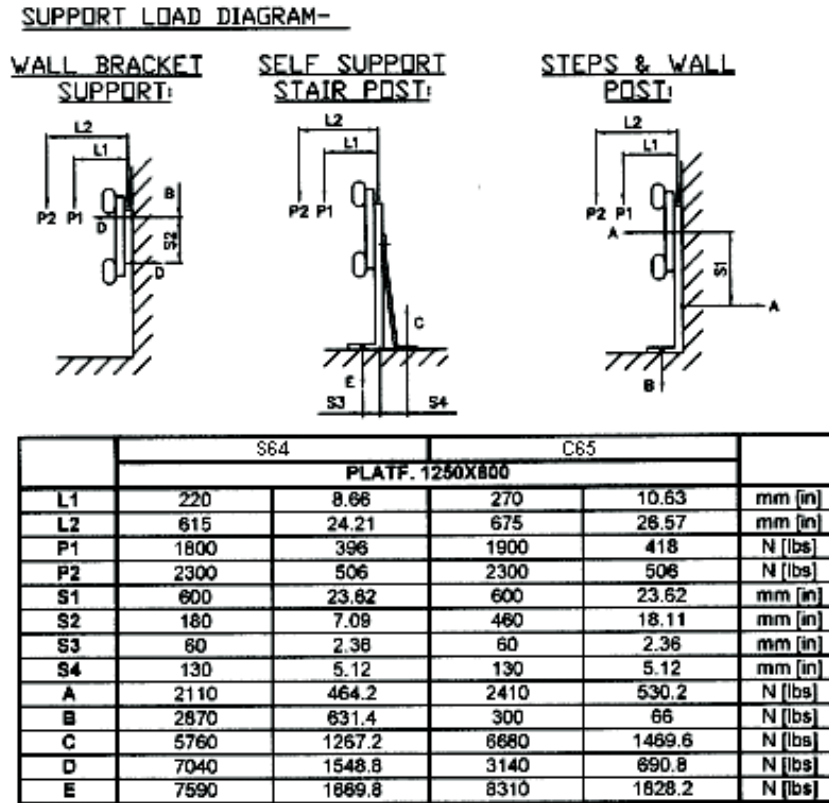

Rail

Where required, the rail must be securely fastened to the structural support wall. Refer to the wall diagram and lag dimensions shown below. Note that this information is provided on sheet 2 of your installation drawings.

Figure 7: Wall Diagram and Lag Dimensions

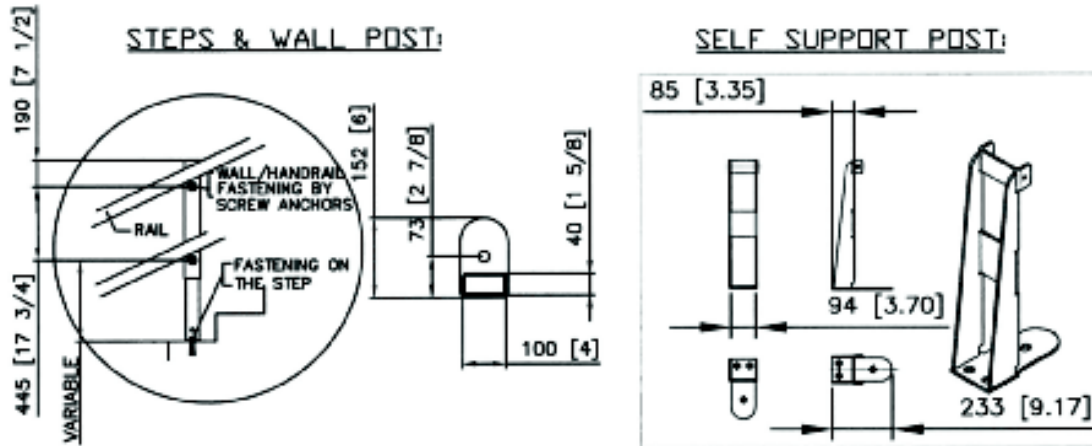

Electrical

General

Electrical equipment and wiring to comply with Section 38 of CSA C22.1 (Canada) or Section 620 of NEC ANSI/NFPA 70 (USA).

Power Supply

120 VAC, 15A, 60 Hz, single phase circuit through a fused disconnect with auxiliary contact on the main power power supply. There must be two 18 AWG conductors between the contact and the controller.

Lighting

Lighting must be a minimum of 100 Lux at the platform and landings and must have a switch and electrical GFCI outlet. Emergency lighting of 2 Lux must be provided for a minimum of one hour on the platform along the travel route.

Sample Installation Drawings

The next two pages provide sample installation drawings. The first page provides plan and elevation views and the second page is the data sheet. Dimensions are identified in the format of mm (inches) unless otherwise specified.

NOTE: These are SAMPLE installation drawings only. Be sure to refer to the site-specific installation drawings that came with your lift for the correct dimensions and specifications.

Figure 8: Sample Installation Drawings (Sheet 1)

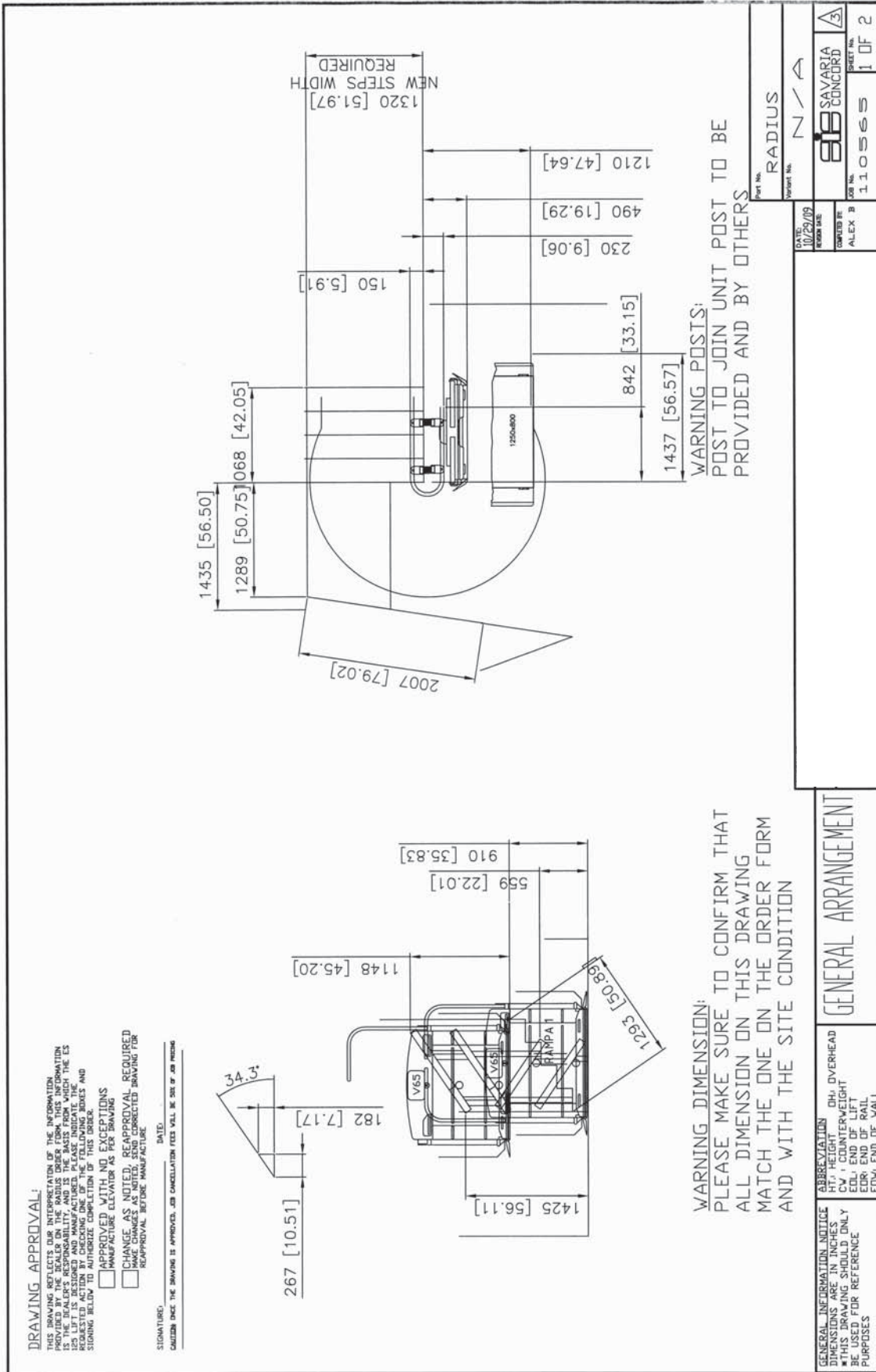
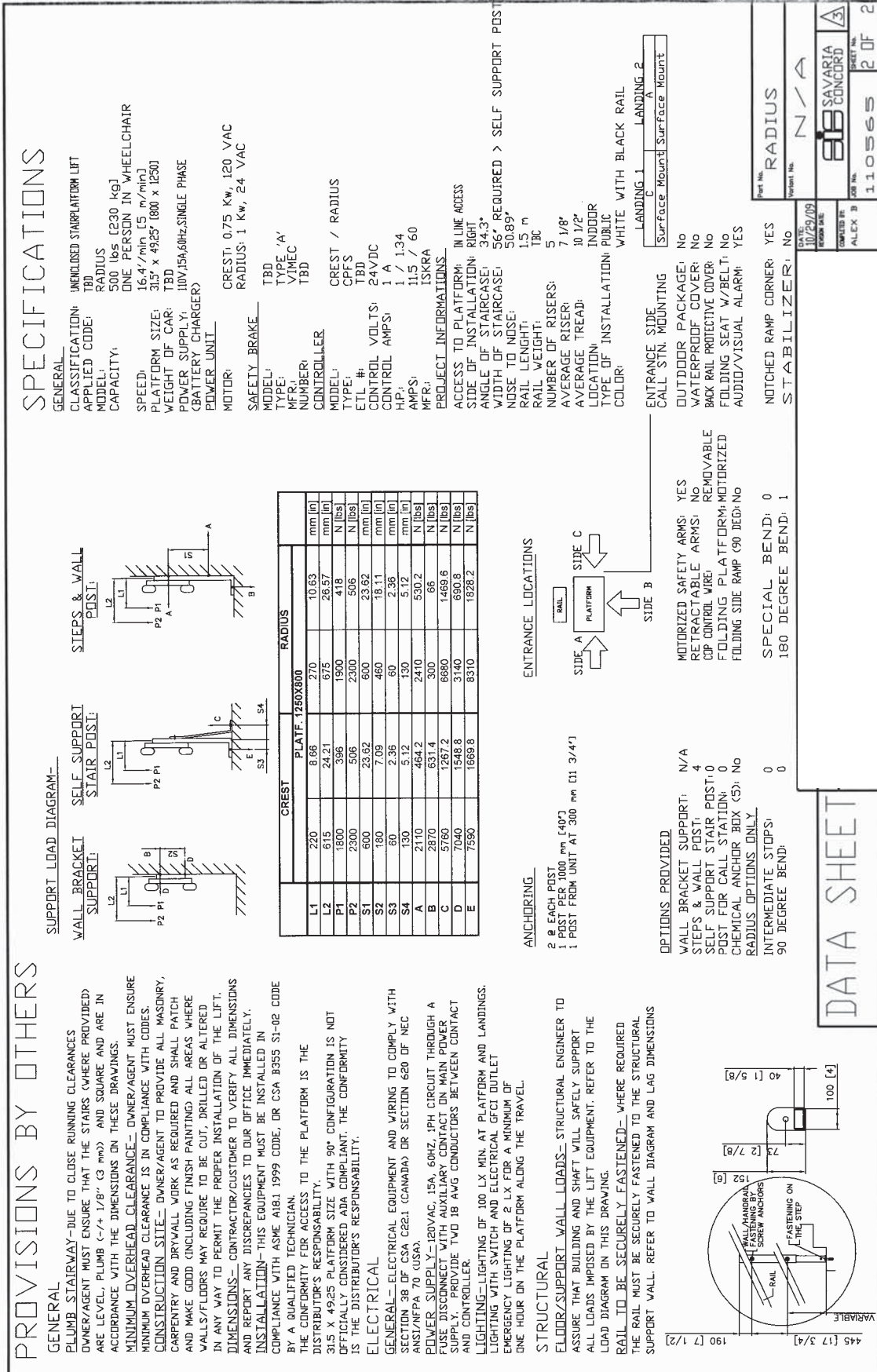

Figure 9: Sample Installation Drawings (Sheet 2)



C65

Inclined Platform Lift

PLANNING GUIDE

Part No. 000722
Copyright © 2010

Savaria Corporation
Lifts and Elevators
www.savaria.com

Sales
107 Alfred Kuehne Blvd.
Brampton, Ontario, L6T 4K3, Canada
Tel: (905) 791-5555
Fax: (905) 791-2222
Toll Free: 1-800-661-5112

